

OPTRAPONS 150 RM - Hand-held branchpipe with adjustable flow-rate and jet

DESCRIPTION

The **OPTRAPONS 150 RM** is a fire-fighting hand-held branchpipe, DMR type, with adjustable flow-rates and jets. High pressure nozzle, manoeuvrable up to 20 bar.

The Optrapons hand-held branchpipe is composed of the following parts :

- A swivelling inlet coupling to be connected at the hose.
- Full bore ball-valve to open/shut off.
- A flow-rate selector, adjustable by rotation with 3 positions : 30, 100, 150 l/min at 6 bar and a flush position distinguishable by its position distant from the flow-rate positions.
- Jet selector that allows adjusting the jet continuously from the straight jet to the protection wide spray jet with a maximum angle of 110°.

The flash over angle of jet is calibrated at 50° ±20° on the flow-rate position of 150 l/min at 6 bar. It can also be used for additives and low expansion foam diffusion.

This hand-held branchpipe has been designed to provide a maximum comfort of use and an optimum jet quality. The pattern quality of straight stream as well as wide fog is exceptional. Its ergonomics has been especially designed and its recoil effect reduced. The reliability has been significantly increased due to the number and the quality of components. This simple and durable design offers a low maintenance.



STANDARDS

Hand-held branchpipe, **type 3**, in compliance with the **NF EN 15182-1** and **NF EN 15182-2** standards. GFR coupling in compliance with the **NF S 61.701** standard and other national standards.

Hand-held branchpipe certified according to the **MED 2014/90/EU - SOLAS 74**.



CONSTRUCTION

Aluminium alloys of first fusion with heat-treatment.

Protection against corrosion with black hard anodizing process.

Pistol grip and flow-rate selector in synthetic materials.

Ball-valve in nickel-plated brass mounted with PTFE rings.

Rings and gaskets in NBR rubber. Other parts in stainless steel.

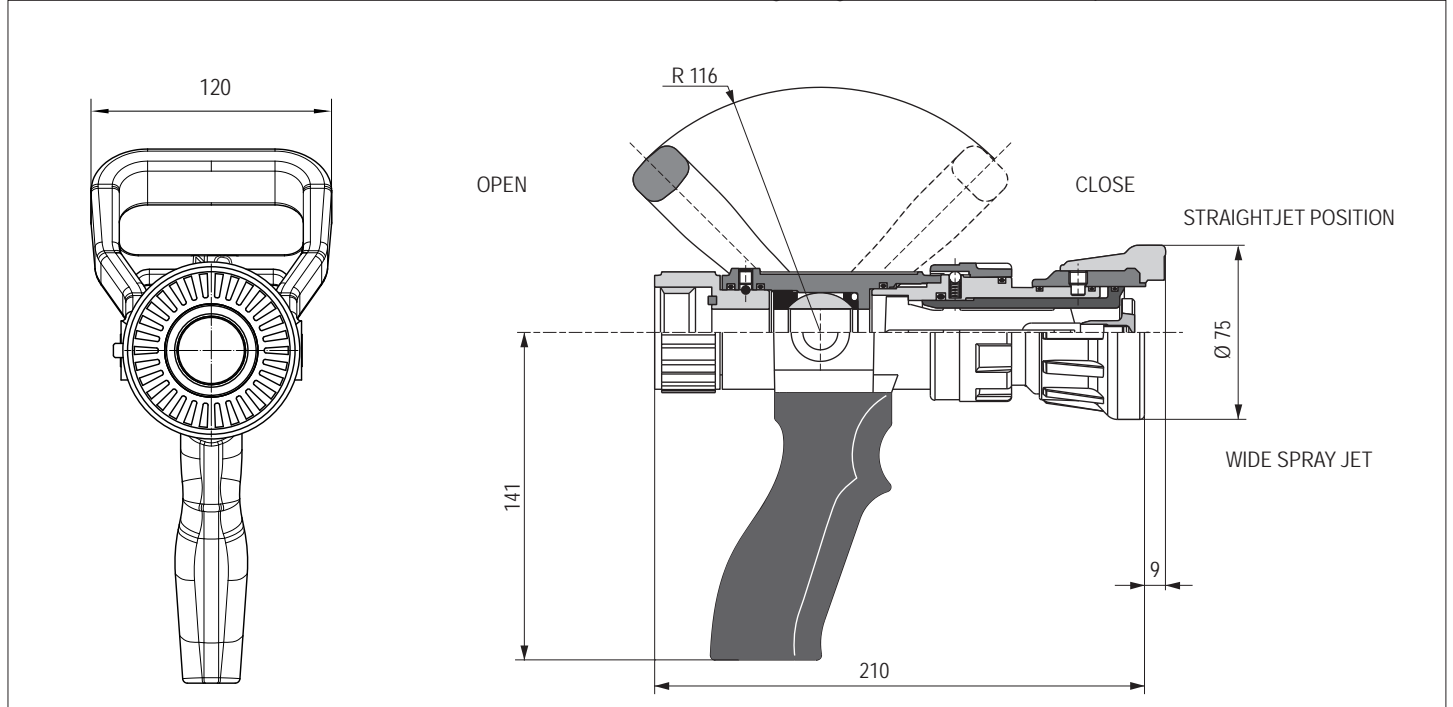

CHARACTERISTICS

Part number	Inlet	Weight (kg)
3040.511RM	GRF F 20	1,360
3040.508RM	Female G 1	1,415
3040.512RM	STORZ C.52	1,820
3040.565RMG	GOST 50	1,750

Flow-rate (l/min)	Throw ranges with straight jet (m)	
	horizontal at 30°	vertical at 80°
30	15	11
100	23	17
150	26	19

Performances tested at 6 bar - Effective throw range in meters. Maximum pressure of use 16 bar.

OPTRAPONS 150 RM - Hand-held branchpipe with adjustable flow-rate and jet

CAUTION

Use the **OPTRAPONS RM 150** only for what it has been designed initially.

 **Do not use on electrical fires.**

USE

The **Optracons RM 150** must be used by trained person and knowing the effects due to the recoil force and the impact force of the jet.

Always use the **Optracons RM 150** to the pressures and flow rates recommended by the operating regulations.

MANUFACTURER WARRANTY

The **Optracons 150 RM** is guaranteed for 10 years against manufacturing defects

PREVENTIVE MAINTENANCE

- After each intervention, especially with liquids that may cause damages (sea water, foam compound, additives, etc ...):
- Rinse the branchpipe with clean water (inside and outside)
- Control the main functions of the branchpipe :
 - fitting swiveling inlet,
 - opening and closing of the valve,
 - flow-rate selector,
 - pattern selector.

CORRECTIVE MAINTENANCE

The swiveling connection no longer rotates or leaks :

Check that no foreign body is stuck between the coupling (**Rep. 2**) and the body (**Rep. 25**).

- Dismounting the coupling (**Rep. 2**) :
 - loosen and remove the screw (**Rep. 5**),
 - remove the balls (**Rep. 26**) by turning the coupling.
- Mounting the coupling (**Rep. 2**) :
 - change both seals (**Rep. 4**),
 - clean and lubricate the throat balls (**Rep. 26**) and the seals (**Rep. 4**) (Loctite 8104),
 - introduce the ball by rotating the coupling,
 - assemble and glue the screws (**Rep. 5**) (Loctite 225).

The valve leaks on the «close» position :

Check that no foreign body is stuck in the ball (**Rep. 7**).

- Removing all tap :
 - disassemble the swivel coupling (**Rep. 2**) (see § 1 : swiveling connection),
 - loosen and the ring (**Rep. 6**),
 - remove the pins (**Rep. 28**),
 - extract the ball (**Rep. 7**),
 - extract the pins inward (**Rep. 27**).
- Reassembling the tap :
 - put the support ring (**Rep. 8**) with its seal (**Rep. 9**) in place in the body (**Rep. 25**),
 - put the handle (**Rep. 3**) in the open position,
 - position the pins (**Rep. 27**) with seals (**Rep. 29**) grease Loctite 8106),
 - assemble the ball (**Rep. 7**) and locking ring (**Rep. 6**) by aligning with a tool Ø 20,
 - drill set (handle - pin) with a drill Ø 3.1,
 - put the pin back in its position (**Rep. 28**).

The flow switch is no longer rotating :

- note the position of the selector,
- loosen the shoe (**Rep. 20**) and the axis (**Rep. 21**),
- slide forward the selector (**Rep. 12**) paying attention to the spring (**Rep. 11**) and the ball (**Rep. 10**),
- clean the bearing surface,
- change the seal (**Rep. 4**) and grease (Loctite 8106),
- handing back all be in the same position as before disassembly, glue (Loctite 225) between pins **20-21** and **20-12**.

The pattern selector in no longer rotating :

- exit the sleeve (**Rep. 15**) forward by identifying the indexing's position ,
- unscrew the skids (**Rep. 19** and **30**) paying attention to the spring (**Rep. 11**) and the ball (**Rep. 10**),
- pull out the pattern selector (**Rep. 14**),
- clean the bearing surface,
- change the seals (**Rep. 18** and **31**),
- mount everything together by greasing the seals (Loctite 8106) and pasting the skids (**Rep. 19** and **30**) (Loctite 225), for the pad (**Rep. 19**) tighten to contact ramps body (**Rep. 13**) and loosen 1/8 turn.

COMPONENTS AND SPARE PARTS

Rep.	Qty.	Designation	Material	Rep.	Qty.	Designation	Material
1	1	GFR ND 20 gasket	Nbr	18	2	Ring R 35-30-2,5	Nbr
2	1	Swivelling coupling (black hard anodized)	Alu	19	1	Pattern selector pin	Bze
3	1	Handle	Pa	20	1	Flow-rate selector pin	Bze
4	4	Ring I 45-39-3	Nbr	21	1	Flow-rate selector axis	Stainless steel
5	1	Screw St M6-6 flat head	Stainless steel	22	1	Jet rectifier	Stainless steel
6	1	Threaded ring	Pa	23	1	Screw, CHC M8x60 A4-80	Stainless steel
7	1	Ball valve	Brass	24	1	Pistol grip	Pur
8	1	Hold ring	Pa	25	1	Stop valve body, anodized	Alu
9	2	R 21 Ring	Nbr	26	28	Ball Ø 4	Stainless steel
10	2	Ball Ø 5	Stainless steel	27	2	Drive pin	Brass
11	2	D5 spring d0,8 HL8	Stainless steel	28	2	Pin G07 3-22	Steel
12	1	Flow-rate selector, anodized	Alu	29	2	R 9 ring	Nbr
13	1	Indexable ramp body, anodized	Alu	30	1	Indexing block	Bze
14	1	Pattern selector, anodized	Alu	31	1	Ring I 35,06-29,82-2,62	Nbr
15	1	Protection head	Pur	E1	1	Valve sticker	
16	1	Sliding tube, anodized	Alu	E2	1	Flow-rate sticker	
17	1	Cap, anodized	Alu	E3	1	Jet selector sticker	



OPTRAPONS 150 RM - Hand-held branchpipe with adjustable flow-rate and jet

